

TEMPERATURE SENSOR

T-145

Applications:

Temperature sensor for measurement of liquids, gases, solid bodies.

Technical Data

Measuring range	up to 400°C
Resistance element:	Pt100 up to PN-EN 60751+A2 Pt1000, Pt500
Protection tube material	stainless steel 1H18N9T (1.4541)
Connection line	2, 3 or 4 wire
Terminal head type	GDS, GDM up to DIN43650; IP65
Terminal head ambient temperature	-30°C to 90°C



Ordering code

T	-	145	-		-		-		-		-	
Protection tube dia. d		∅ 6 mm		6		others						
Protection tube length Lc		100 mm		100		others						
Connection line		2-wire, 3-wire, 4-wire		2								
Tolerance class - A, B												e.g. B
Measuring insert		Pt100, 2xPt100, others										e.g. Pt100
Operating temperature		80°C, 200°C, others										e.g. 200°C

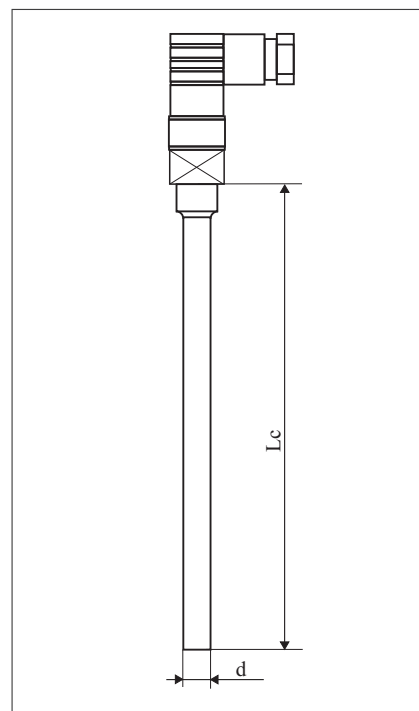
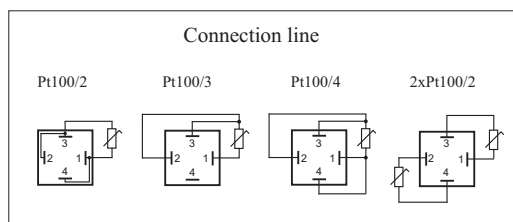

Order example:

T-145-6-100-2-B-Pt100-200°C - sensor of protection tube diameter d=6 mm, length Lc=100 mm, 2-wire, class B, Pt100, operating temperature 200°C.